

TOS5101

Hipot Tester

Basic model series with excellent cost performance.



TOS5101(AC/DC)



**High-end model of TOS series having AC, DC10kV output
Conforming to demands of various component standards
testing and margin test**

TOS5101 is designed exclusively for withstand voltage testing of electronic equipment and components conforming to various safety standards. The use of a high luminance, large fluorescent display tube for the display enables data including measured values, status and judgment results to be extremely legible. The PASS/FAIL function employs a window comparator method that enables TOS5101 to make fail judgment of current leakage over the upper reference value and below the lower reference value which can be set on the front panel.

Thus, highly reliable testing can be performed including that for test lead disconnection and defective contact. In addition, in order to prevent erroneous operation and accidents, the TOS5101 is also equipped with a Key Lock function and Interlock function, a high-voltage output terminal having a narrowed insertion port, a large DANGER lamp, and an automatic discharge function (during DC operation) that removes charge from the test piece. These features give the TOS5101 a high degree of safety and reliability.

- Complies with various safety standards
- AC/DC output (0 to 10 kV)
- Large color display
- Digital voltmeter and ammeter
- Digital timer
- Window comparator type employed for PASS / FAIL judgement.
- Equipped with remote control function
- Various signal outputs
- Automatic discharge function (during DC operation)
- Provided with zero turn-on switch
- Compact size

TOS5101

Hipot Tester

Output block	
Applied Voltage	0 to 5/0 to 10 kV AC and DC
AC	
Maximum Rated*1	500VA / 10 kV, 50 mA
Waveform	Commercial line waveform
Voltage Regulation	Max. 15% (for max. rated load to no load)
Switching	Use of a zero turn-on switch
DC	
Applied Voltage	50W / 10 kV, 5 mA
Ripple	100 Vp-p typ. at 10 kV, no load 200 Vp-p typ. at max. rated output
Maximum Rated*1	Max. 3% (for max. rated load to no load)
Output Voltmeters	
Analog	
Scale	10 kV full scale , AC/DC
Class	JIS Class 2.5
Accuracy	±5% of full scale
AC Indication	Mean value response / rms value scale
Digital	
Full Scale	5 kV/ 10 kV full scale
Accuracy	±1.5% of full scale
AC Response	Mean value response / rms value display
Ammeter	
Digital	
Accuracy	±(5% + 20μA) of upper cutoff current
AC Response	Mean value response / rms value display
Pass/fail Judgement Function	
Type of Judgement	Window comparator type ● FAIL judgement *When current detected above upper cutoff current *When current detected below lower cutoff current (FAIL signal generated when FAIL judgement made) ● PASS judgement *When set time has elapsed and no abnormality is detected
Upper cutoff current setting range	AC: 0.1 to 55 mA DC: 0.1 to 5.5 mA
Lower cutoff current setting range	AC: 0.1 to 55 mA DC: 0.1 to 5.5 mA
Judgement Accuracy	±(5% of upper cutoff current + 20μA)
Current Detection	Integration of current absolute value followed by comparison with reference value.
Calibration	With rms value of sine wave using a pure resistance load.
No-load output voltage required for detection	Approx. 970 V when set to 50 mA AC Approx. 160 V when set to 5 mA DC
Test Time Setting Range	0.5 to 999 sec (±10 ms) (timer-off function provided)
Accuracy	±20 ms
Line Voltage	100V±10%, 50/60 Hz (Nominal voltages of 110V, 120V, 220V, 230V and 240V available as factory options.)
Power Requirements	
for line voltage of 100 V	Max. 50 VA under no-load conditions / Approx. 600 VA at rated load
for line voltage of 100 V to 200 V	Max. 50 VA under no-load conditions / Approx. 600 VA at rated load
for line voltage of 220 V to 240 V	Max. 50 VA under no-load conditions / Approx. 610 VA at rated load
Electromagnetic compatibility (EMC)	Conforms to the requirements of the following directive and standard.*2 EMC Directive 89/336/EEC EN61326 EN61000-3-2 EN61000-3-3 Under following conditions 1. Used HV test leadwires which is supplied. 2. No discharge in testing. 3. Used the shielded cable which length is less than three meters when the SIGNAL I/O is used.

Safety	Conforms to the requirements of the following directive and standard. *2,4 Low Voltage Directive 73/23/EEC EN61010-1 Class I Pollution degree 2
Insulation resistance	30 M Ω or more (500 V DC)
Hipot	1390 VAC, 2 seconds [between the AC LINE and chassis] 1200 VAC, 1 second [UL-approved products only]
Environment	Specification range : 5 °C to 35°C / 20 %rh to 80 %rh Operable range : 0 °C to 40°C / 20 %rh to 80 %rh Storage range : -20 °C to 70 °C / 80 %rh or less
Dimensions (MAX)	430W × 177(195)H × 370(450)Dmm
Weight	
for line voltage of 100 V	Approx. 21 kg
for line voltage of 100 V to 120 V	Approx. 23 kg
for line voltage of 220 V to 240 V	Approx. 24 kg
Accessories	
High-voltage test lead	TL01-TOS (max.allowablevoltage: 5 kV /1.5m) TL03-TOS (max.allowablevoltage: 10 kV /1.5m)
Others	14-pin amphenol plug (assembled)

- *1: Continuous output time may be limited depending on current high limit reference value and ambient temperature.
*2: Only on models that have CE marking on the panel. Not applicable to custom order models.
*3: Not applicable to custom order models.
*4: This instrument is a Class I equipment. Be sure to ground the protective conductor terminal of the instrument. The safety of the instrument is not guaranteed unless the instrument is grounded properly.

External dimensional diagrams

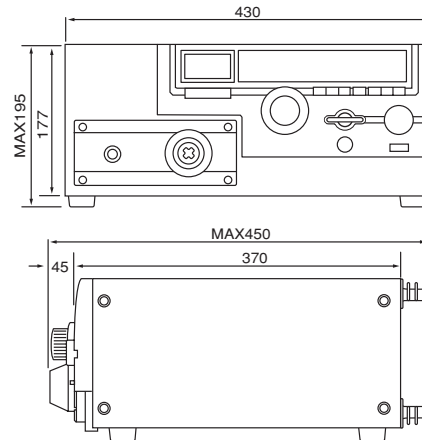

Unit: mm

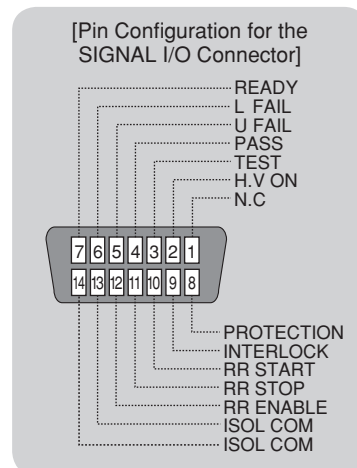



KIKUSUI ELECTRONICS CORPORATION

1-1-3, Higashiyamata, Tsuzuki-ku, Yokohama, 224-0023, Japan
Phone: (+81) 45-593-7570, Facsimile: (+81) 45-593-7571, www.kikusui.co.jp

KIKUSUI AMERICA, INC. Toll Free **1-800-KIKUSUI** www.kikusui.us



1744 Rollins Road, Burlingame, CA 94010
Phone : 650-259-5900 Facsimile : 650-259-5904

KIKUSUI TRADING (SHANGHAI) Co., Ltd. www.kikusui.cn



Room, D-01,11F, Majesty Bld, No.138, Pudong Ave, Shanghai City
Phone : 021-5887-9067 Facsimile : 021-5887-9069

For our local sales distributors and representatives, please refer to "sales network" of our website.

Recycled Paper

●Distributor:

■ All products contained in this catalogue are equipment and devices that are premised on use under the supervision of qualified personnel, and are not designed or produced for home-use or use by general consumers. ■ Specifications, design and so forth are subject to change without prior notice to improve the quality. ■ Product names and prices are subject to change and production may be discontinued when necessary. ■ Product names, company names and brand names contained in this catalogue represent the respective registered trade name or trade mark. ■ Colors, textures and so forth of photographs shown in this catalogue may differ from actual products due to a limited fidelity in printing. ■ Although every effort has been made to provide the information as accurate as possible for this catalogue, certain details have unavoidably been omitted due to limitations in space. ■ If you find any misprints or errors in this catalogue, it would be appreciated if you would inform us. ■ Please contact our distributors to confirm specifications, price, accessories or anything that may be unclear when placing an order or concluding a purchasing agreement.

Printed in Japan

Issue:Feb.2008

2008021KCMEC41